

Lewis® Sulphuric Acid Valves

Gate Valve

Technical Specifications

WEIR

Minerals



Our Lewis® range of pumps, valves and alloys are a trusted partner in the sulphur, sulphuric acid and phosphoric acid industries.

Our Lewis® range of products includes pumps, valves and alloys, including the family of Lewmet® alloys. These specialty alloys are designed to specifically provide superior erosion resistance combined with outstanding corrosion protection in the operating environment of contact process sulphuric acid producing plants.

Specified for hot acid service where tight shut-off is mandatory

Lewis® gate valves are designed with an all metal construction featuring Lewmet® nickel chrome alloys. Lewmet® alloys are highly specialised metallurgy for the harsh sulphuric acid environment. Lewis® gate valves are often specified for hot acid service where tight shut-off is mandatory and cannot be compromised.

Lewis® valves can be furnished with a variety of automatic actuators.



Lewis® gate valves featuring Lewmet® alloy are designed to provide unequalled performance in sulphuric acid plant operations.

Design Features

- Robust materials of construction to combat the effects of a corrosive environment
- Class IV shut-off

Design Standards

Drilled to ANSI, BS, DIN, or, JIS standards

Specifications

All Lewmet® alloy construction sizes 1-100 mm (½" - 4")

Alloyed iron body, Lewmet® alloy discs and seats sizes 150-750mm (6" - 30")

Temperature 140°C (280°F)/HRS: 240°C (460°F)

Materials

Lewmet® alloy and stainless steel

Lewis® Gate Valve Dimensions

SIZE		A		B				C		D	
in	mm	in	mm	OPEN		CLOSED		in	mm	in	mm
0.5	12	4.25	117	9	229	8	203	4	102	0.375	29
0.75	19	4.625	117	9	229	8.125	206	4	102	0.5	32
1	25	5	127	11.5	292	9.625	244	4	102	0.5	35
1.5	37	6.5	165	14	356	11.75	298	6	152	0.563	14
2	50	7	178	14.5	368	11.75	298	6	152	0.625	16
3	75	8	203	19.5	495	16	406	10	254	0.75	19
4	100	9	229	23.25	591	18.75	476	10	254	0.938	41

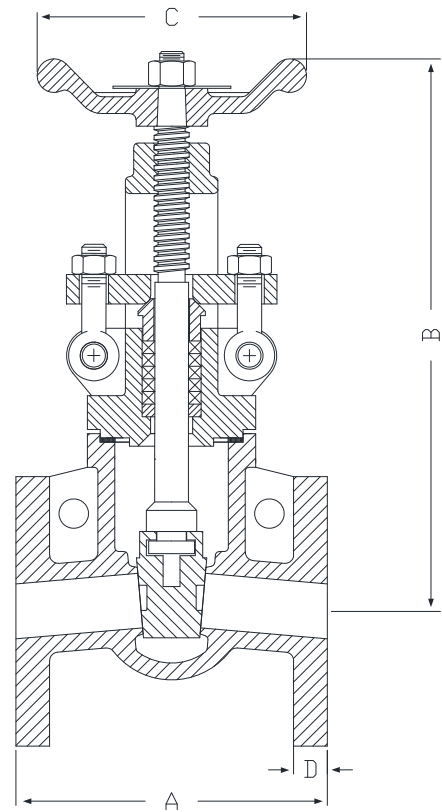

Lewis® Double Disc Gate Valve Dimensions

SIZE		A		B				C		D	
in	mm	in	mm	OPEN		CLOSED		in	mm	in	mm
6	150	10	267	32	810	25	640	12	305	1.125	29
8	200	11.5	292	42	1070	33	840	14	356	1.25	32
10	250	13	330	50	1270	39	990	18	457	1.375	35
12	300	14	356	55	1400	42	1070	18	457	1.5	38
14	350	15	381	67	1700	52	1320	24	610	1.625	41
16	400	16	406	72	1830	55	1400	24	610	1.625	41
18	450	17	432	82	2080	63	1600	30	762	1.75	44
20	500	18	457	89	2260	68	1730	30	762	1.75	44
24	600	20	508	108	2740	83	2110	36	914	1.875	48
30	600	24	610	132	3353	102	2591	36	914	2.125	54

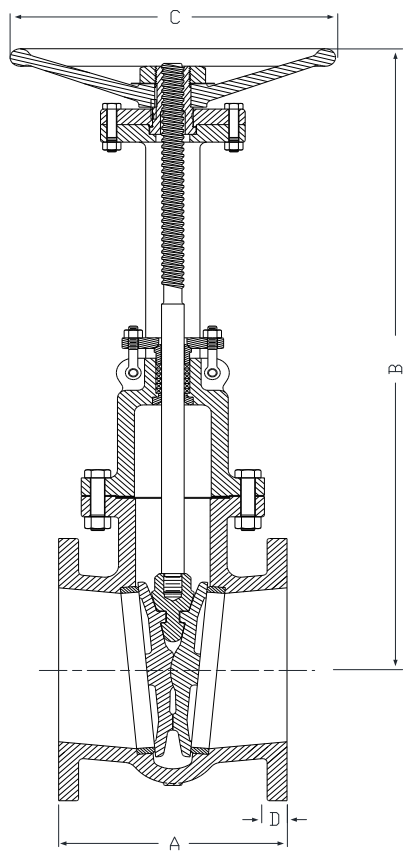

Weir Minerals
 8625 Grant Rd.
 St. Louis, MO 63123
 USA

+1 314 843 4437
 lewis@mail.weir

www.lewis.weir